

or

Connector 15 Pin D-Sub

- 1 Drive Coil black (1) low Shield
- 2 Drive Coil transparent (1) high
- 3 Position Output negativ transparent (2)
- 4 Ground (GND) black (2) Shield
- 5 Heater +/- red (1) } 86 Ohm
- 7 Heater (low) blue (1) }
- 8 Oscillator supply volt. 12 VDC red (2)
- 9 Drive Coil black (1) low Shield
- 10 Drive Coil transparent (1) high
- 11 Position Output positiv blue (2)
- 15 Thermistor +/- yellow (2)  
500 Ohm at 25 deg. cel.

(1) = Cable 1  
(2) = Cable 2

Scanner Connections 15 Pin D-Sub  
Cables 300 mm long

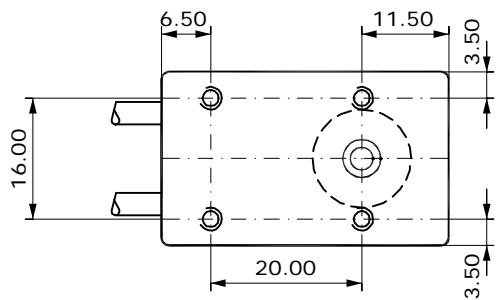

**Caution**  
Don't screw in the upper fixation screw deeper than **5mm** otherwise the inner parts will be destroyed.

**Specifications**

Optical Angle (deg.)	50
Coil Resistance parallel (ohm)	3.2
Linearity (%)	+/-0.20
Repeatability (mrad)	0.10
Zero Drift (mrad/deg. cel.)	0.60
Wobble (mrad)	0.02
Maximum Torque (Nm)	0.06
Typical Mirror Size (mm)	up to 25x35x2
Life time (cycles)	10 <sup>10</sup>
Weight (g)	200

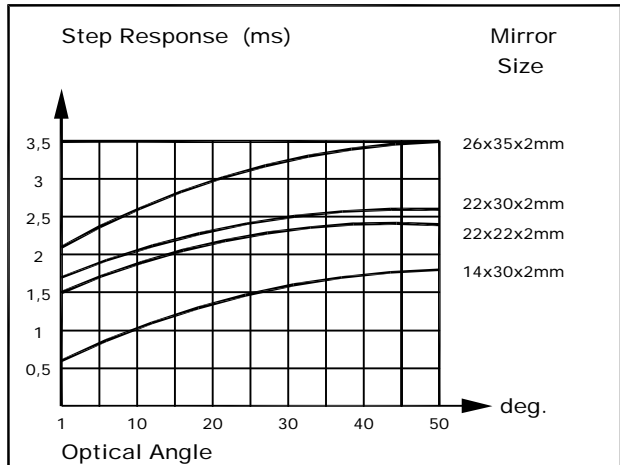

Measured with LSK Scanner-Driver and Mirrormount.